



P.P.U.H. „Geco” spółka z o.o.  
30-134 Kraków ul. Zarzecze 112 A  
tel. 012 6369811, 6361290  
fax. 012 6362002

***SERVICE & OPERATING INSTRUCTIONS  
FOR AUTONOMOUS CONTROL UNIT***

**G-403-P04**

***TO CONTROL SYSTEMS  
WITH SOLAR COLLECTORS***

*version 02*

***Please read these instructions very carefully before connecting and starting any of our equipment. If in doubt, please contact our company between 8:00 a.m. - 4:00 p.m.***

***Note!!! The last updating of the manual is marked at the bottom of each of the following pages. Please always use the latest version of the manual which you may obtain free of charge by mail upon request.***



## CONTENTS:

<b>1.</b>	<b>GENERAL CHARACTERISTICS.....</b>	<b>4</b>
<b>2.</b>	<b>TECHNICAL DATA .....</b>	<b>4</b>
<b>3.</b>	<b>ELECTRIC INSTALLATION AND THE RULES OF CONNECTION.....</b>	<b>5</b>
<b>4.</b>	<b>OPERATION AND THE METHOD OF CONTROL OF SBR G-403-P04.....</b>	<b>5</b>
4.1.	MEASUREMENT OF TEMPERATURE.....	5
4.2.	DISCONNECTION OF THE FEEDING VOLTAGE .....	5
<b>5.</b>	<b>OPERATION OF G-403-P04.....</b>	<b>6</b>
5.1.	ACTIVATION OF THE UNIT .....	6
5.2.	MANUAL (MASTER) OPERATION.....	6
5.3.	AUTOMATIC OPERATION .....	7
5.4.	TEMPERATURE VIEW.....	7
5.5.	ALARMS .....	7
<b>6.</b>	<b>COFIGURATION OF USER PARAMETERS.....</b>	<b>8</b>
<b>7.</b>	<b>CONFIGURATION OF THE TYPE OF CONTROLLER .....</b>	<b>8</b>
<b>8.</b>	<b>THE CONTROLLER SYSTEM.....</b>	<b>10</b>
8.1.	A BASIC SYSTEM WITH ONE CONTROLLER.....	10
8.2.	A SYSTEM WITH ONE COLLECTOR AND OPERATION OF THE PUMP FOR THE CENTRAL HEATING BOILER.....	10
8.3.	A SYSTEM WITH ONE COLLECTOR AND OPERATION OF THE PUMP FOR THE CWU.....	11
8.4.	THE SYSTEM WITH ONE COLLECTOR AND SWIMMING POOL HEATING .....	11
8.5.	A SYSTEM WITH TWO COLLECTORS.....	12
8.6.	A SYSTEM WITH ONE COLLECTOR AND A FLOOR HEATING SYSTEM .....	13
<b>9.</b>	<b>TROUBLESHOOTING.....</b>	<b>16</b>

## 1. GENERAL CHARACTERISTICS.

An autonomous control unit G-403-P04 is used to control pump operation and to stabilise temperature in systems with solar collectors.

The G-403-P04 controller is a convenient, modern and easy to operate unit. It was made using a microprocessor technology with automatic surface installation.

Depending on the method of installation the two-part casing allows to install the control panel operated at safe voltage practically at any place without the necessity to mount feeding cables far away from the controlled units.

The G-403-P04 controller is provided with:

- Three temperature sensors:
  1. to measure the temperature of the solar collector,
  2. to measure the temperature of the isothermal tank,
  3. to measure additional temperature depending on the configuration.

It has also outlets which allow to connect units which are operated at voltage 230 V directly, including: the PK main collector pump, an additional pump (PKT,PC,PK2) or a three-way valve (ZT,ZP)

Adjustable parameters can be set in current operation conditions and in accordance with the type of installation. The controller is provided with a system which protects it against the effects of blackouts and various types of disturbances.

The controller does not require any special maintenance, the keyboard is made from special foil which is resistant to high temperature and most chemicals. Cleaning of the keyboard with sharp objects is not allowed; cleaning of the face of the keyboard with a wet cloth from time to time will be sufficient.

In summer the controller should remain connected to mains, nevertheless, it should be disconnected from mains during storms.

## 2. TECHNICAL DATA

operating voltage	—	230V +10% -15%
temperature	—	from +5°C to +40°C
humidity	—	from 20% to 80% RH
protection degree	—	IP65 from the front of the control panel

### ⚠ CAUTION!!!

On every casing is a sticker with:

- the serial number
- a description of outlets and their load-carrying capacity
- SBR type

**Total current drawn by the unit can not exceed 10A!!!**

### 3. ELECTRIC INSTALLATION AND THE RULES OF CONNECTION

1. The room in which the controller is connected should be provided with electric circuit 230V/50Hz in accordance with effective regulations.
2. The electric circuit (regardless of its type) should be ended with a plug-in socket provided with a protective contact. **Use of a socket without a protective clamp may cause an electric shock!!!**
3. The controller should be connected to a separate electric line protected with a 2-4A quick-break fuse and an antishock circuit-breaker with maximal activating current 30 mA. **Do not connect any other equipment to this circuit!!!**
4. The clamping couplings have a permanent 16 A load certificate!!! They have a fine thread and special plates which prevent wire cutting, therefore, light tightening of a wire results in a maximally good contact and use a bigger force may cause a damage of the thread.
5. Electric cables have to be well-fastened along their whole length and can not touch pipes with glycol, the tank or pumps.
6. When the unit is connected to mains, live current can be in cables regardless whether the button  is on or off, therefore **ALL REPAIRS must be done when power is disconnected on the fuse!!!**

#### **Caution!!!**

**Additional equipment may be connected to the G-403-P04 controller only by a person authorised to do electric installation works.**

### 4. OPERATION AND THE METHOD OF CONTROL OF SBR G-403-P04

#### 4.1. Measurement of temperature

The controller measures temperature within the range from 0°C to 100°C. It is displayed with a delay of 1 second. If there is a breakdown of temperature sensor or the measured temperature is out of the range defined above (unless the unit is waiting for 60 s for stabilisation of voltage after its disconnection) the controller informs of a breakdown of the sensor which causes that all connected units are switched off (i.e.. the ventilator, the feeder and the pump), the unit is switched into manual operation mode and the sign AL1 is displayed on the display if there is a breakdown of the T1 temperature sensor, AL2 is displayed on the display if there is a breakdown of the T2 temperature sensor and AL3 is displayed on the display if there is a breakdown of the T3 temperature sensor. Temperature of exactly 100°C will cause a display of the sign 00°.

#### 4.2. Disconnection of the feeding voltage

After disconnection of the feeding voltage the controller begins its operation depending on the mode in which it was set before the disconnection. The controller waits for 1 minute for stabilisation of the electric current and returns to operation with parameter values which were programmed before.

## 5. OPERATION OF G-403-P04

### 5.1. Activation of the unit

1. Connect the unit to mains (put the plug in a socket).

First, four dots will appear on the display; then a factory program version will be seen, four dots followed by four horizontal dashes (----) which signal that the unit is in a stand-by position. All functions, in particular all control units connected to the controller which control operation of the controller system, are switched off. In this position the unit does not react to

pressing of any buttons except from the button .

2. Switch on the controller using the button .
3. When the button has been pressed, the controller begins to control pump operation automatically and reads the latest parameters programmed by the user (see item 6). The display shows water temperature measured by the T2 sensor in the isothermal tank.

### 5.2. Manual (master) operation

In the automatic operation mode the user may connect the pump engine manually regardless of the current temperature and set parameters:

1. PK collector pump:



When the button  is pressed, the collector pump connected to the controller is switched on and the **upper** indicator on the button is switched on permanently. When the button is pressed again, forced operation of the pump ends and the controller controls it depending on whether temperature conditions of its operation are met or not. If the pump is switched on automatically, the indicator on the button flashes.

2. An additional pump (PKT,PC,PK2) or a three-way valve (ZT,ZP):



When the button  is pressed, the collector pump connected to the controller is switched on and the **upper** indicator on the button is switched on permanently. When the button is pressed again, forced operation of the pump ends and the controller controls it depending on whether temperature conditions of its operation are met or not. If the pump is switched on automatically, the indicator on the button flashes.

The collector and the additional pump may be switched on and off independently of one another.

### 5.3. Automatic operation

#### 1. PK collector pump operation

A decision on switching on of the PK pump engine is made by the control on the basis of information received from temperature sensors placed in the solar collector (T1) and the isothermal tank (T2). If the difference of temperature of the solar collector and the isothermal tank is a positive figure and bigger than the value set by the user in the 'u0' parameter ( $\Rightarrow$  see: 'Types of controller operation') and the maximal temperature of the tank 'u1' has not been exceeded, the PK main collector pump is switched on and the solar collector is the source of energy which is used to heat water in the tank.



#### 2. Additional pump or a three-way valve operation

An additional pump or a valve are controlled depending on the chosen type of controller and were described in item 8 (Types of controller operation).

When the button  is pressed, the programming mode which does not influence automatic unit operation is chosen.

During a normal (automatic) operation of the engine of a given pump, the diode on the corresponding pump button is flashing and during its forced manual operation it is lit permanently.

### 5.4. Temperature view

The controller offers to the user a possibility to view the temperature in the solar collector. The button  should be pressed to do so. The button  is used to check temperature which is measured by an additional sensor (whose position depends on the programme of the controller).

### 5.5. Alarms



The controller differentiates three types of alarm. In every type of alarm the number of alarm is displayed and an acoustic alarm outlet in the control panel is switched on. Only after pressing of the  button, alarm will end. Automatic operation of the unit can be restarted only after a removal of the defect.

Types of alarms:

- AL1  $\rightarrow$  Damaged temperature sensor of the solar collector (T1)
- AL2  $\rightarrow$  Damaged temperature sensor of the isothermal tank (T2)
- AL3  $\rightarrow$  Damaged additional temperature sensor (T3): location depends on the programme version and the type of installation

When temperature in the isothermal tank defined in the 'u1' parameter is exceeded (a standard temperature is 90 °C) the engine of the PK collector pump is switched off unconditionally.

## 6. COFIGURATION OF USER PARAMETERS

When the button  is pressed, the controller is set in the programming mode which is signalled by switching on of the indicator on the button . Programming does not influence current operation of the controller.

Programming should be done carefully. It is advisable to put down the values of particular parameters on a sheet of paper before the beginning of programming. Please, remember that a mistake in programming may cause a defective operation or make correct operation of the system impossible.

### ***Caution!!***

**The meaning of parameters depends on the type of controller chosen by the installer!!! See: 'Configuration of the type of controller'**





1. Set the required value of parameters using the buttons , .

The permissible range of changes if a given parameter depends on the type of the controller (type of installation).

2. Press the button  again and the new value of a given parameter will be memorised.

The controller automatically moves to programming of the following parameter.

### ***Notes:***

- If the button  is not pressed again, the changes will not be recorded.
- If during setting of the new temperature none of the buttons , , , is pressed within 20 seconds, the new value will not be recorded and the controller will end the programming mode.

This parameter is modified in an analogous way to the one defined in items 6.1 and 6.2.

***When the button  is pressed again, the unit will return to the situation before the beginning of programming and the programming indicator will appear.***







## 7. CONFIGURATION OF THE TYPE OF CONTROLLER

The type of the controller depends on the needs of installation in which it is to operate. To change the configuration of the type of the controller, do as follows:



1. Switch off the controller with the button .

Four horizontal dashes will appear on the display.



2. Press the three buttons: , ,  at the same time for about 3 seconds. The controller moves to the programming mode which is signalled by switching on of an indicator on the button  and appearance of the 'c0' symbol followed by the value of that service parameter.
3. The 'c0' parameter means the choice of the type of controller (range: 1 – 6):
- '1': basic version with one collector (fig.1),
  - '2': a version with one collector and operation of a pump for the central heating boiler. (fig.2),
  - '3': a version with one collector and operation of a pump for the CWU tank (fig.3),
  - '4': a version with one collector and the function of swimming pool heating through the ZT valve (rys.4),
  - '5': a version with two collectors (fig.5),
  - '6' - : a version with one collector and operation of floor heating through the ZP valve (rys.6),
4. Set the required value of the parameter using buttons  .

When an arrow is being pressed for a longer time the value is automatically increased or decreased depending on the chosen direction of changes. Values are interconnected so when you reach the extreme value at one end it goes to the extreme value on the other end.

5. Press  again and the new value of the parameter will be recorded. At the same time the controller turns to reset and then to the stand-by function and the programming indicator on the button  is switched off.
6. Switch the controller on with the button .

The controller will restart its operation according to the newly recorded programme.

When the button  is pressed at any moment, the controller will be switched off without recording the modified parameter in its memory and the control indicator will be switched off.

#### **Notes on programming of SBR:**

1. **THE PRODUCER IS OBLIGED TO INTRODUCE NEW PARAMETERS WHICH ARE NECESSARY FOR NORMAL OPERATION OF THE UNIT!**
2. When the unit is programmed and started up its operation and correctness of the setting of user parameters should be checked.

## 8. THE CONTROLLER SYSTEM

### 8.1. A basic system with one controller

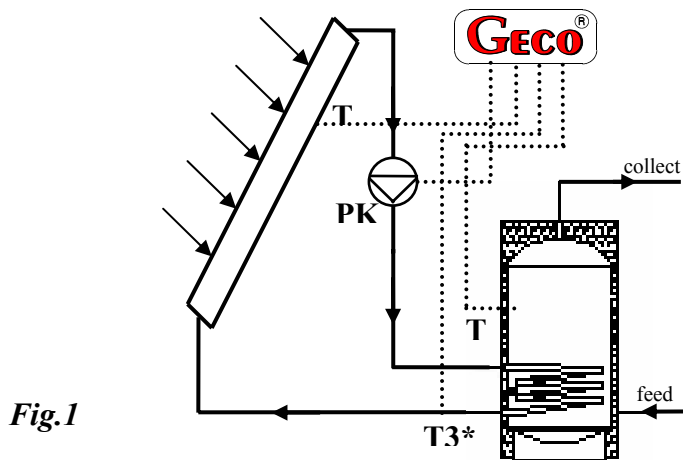

Fig.1

#### Parameters available to the user

- 'u0' – (range 2-30 °C) : temperature difference which controls work of the main collector pump
- 'u1' – (range 10-90 °C): maximal temperature of the isothermal tank above which the collector pump will be switched off

In this system the collector pump is operated in accordance with the description in item 5.3 and the additional pump is not used. If the T3 sensor is not installed, the view of its temperature is blocked and the AL3 alarm from that sensor is not signalled.

### 8.2. A system with one collector and operation of the pump for the central heating boiler.

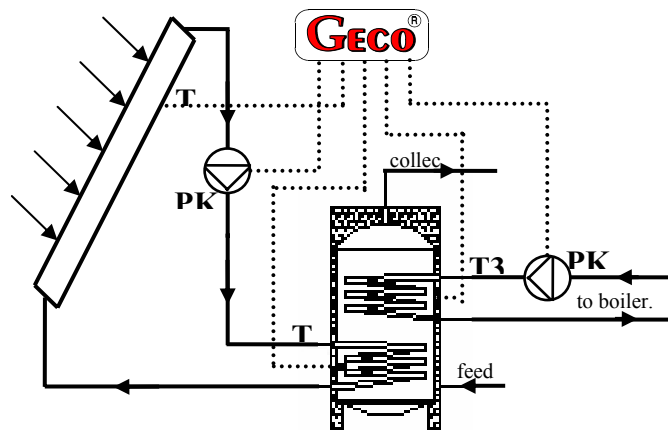

Fig.2

#### Parameters available to the user

- 'u0' – (range 2-30 °C): temperature difference which controls work of the main collector pump
- 'u1' – (range 10-90 °C): maximal temperature of the isothermal tank above which the collector pump will be switched off
- 'u2' - (range 10-90 °C): the temperature below which the PKT boiler pump will be switched on

In this system the collector pump functions in accordance with the description in item 5.3 and the PKT boiler pump is an additional pump. It will be connected if the sensor temperature T3 is lower than the temperature set by the user in the parameter 'u2'.

### 8.3. A system with one collector and operation of the pump for the CWU

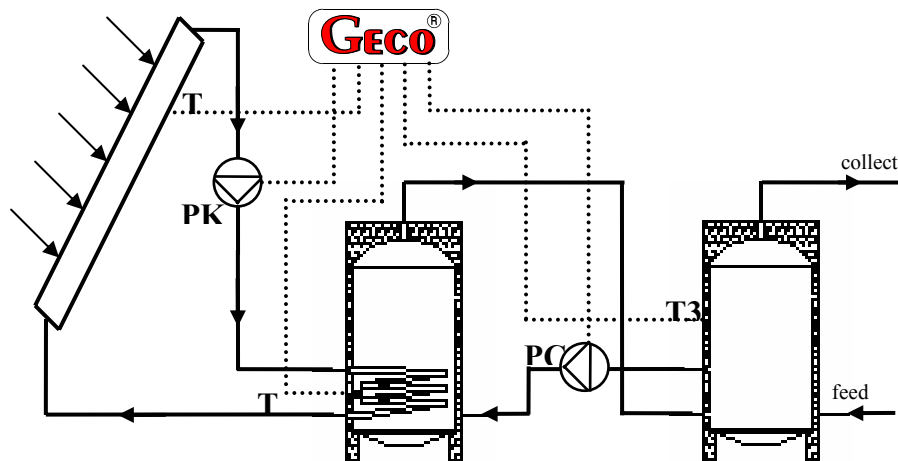

Fig. 3

#### *Parameters available to the user*

- ‘**u0**’ – (range 2-30 °C): temperature difference which controls work of the main collector pump
- ‘**u1**’ – (range 10-90 °C): maximal temperature of the isothermal tank above which the collector pump will be switched off
- ‘**u2**’ – (range 10-90 °C): temperature of CWU tank above which the PC pump is switched off
- ‘**u3**’ – (range 2-30 °C): temperature difference which controls operation of the PC pump for the CWU tank

In this system the collector pump functions in accordance with the description in item 5.3 and the PC pump for the CWU tank is an additional pump. It is switched on if the temperature of the T3 sensor is lower than the temperature set by the user in the parameter ‘**u2**’ **and** the difference of temperature between the isothermal tank (T2) and the CWU tank (T3) is a positive figure, bigger than the value set by the user as the parameter ‘**u3**’.

### 8.4. The system with one collector and swimming pool heating

#### *Parameters available to the user*

- ‘**u0**’ : (range 2-30 °C): temperature difference which controls work of the main collector pump
- ‘**u1**’ : (range 10-90 °C): maximal temperature of the isothermal tank above which the collector pump will be switched off
- ‘**u2**’ - (range 10-90 °C): maximal temperature of the heat exchanger for the swimming pool above which the collector pump (and the ZT valve) will be switched off
- ‘**u3**’ – (range 2-30 °C): temperature difference which controls operation of the ZT tree-way valve
- ‘**u4**’ – (range 0-10 min): duration of the break in operation of PK main pump in order to test temperatures in relation to reheating of water in the isothermal tank (when ‘**u4**’=0 no test is done)

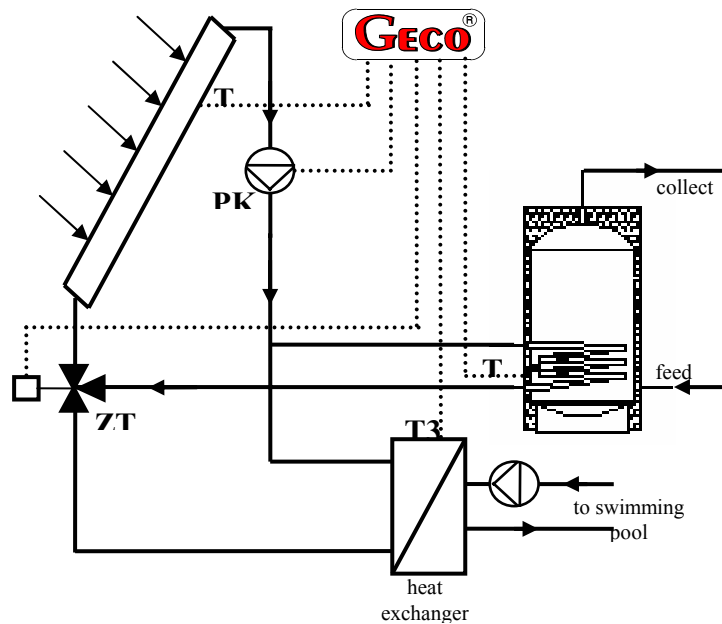

Fig. 4

In this system the collector pump functions in accordance with the description in item 5.3 and the ZT three-way valve is an additional unit. It will be opened (heat pumping to the swimming pool) and the PK main pump will be switched on when:

- the maximal temperature of the isothermal tank set by the user in 'u1' parameter is exceeded **and** temperature difference between the collector (T1) and the swimming pool (T3) is a positive figure and is bigger than the value set by the user in the 'u3' parameter and the maximal temperature in the tank of swimming pool heat exchanger (T3) set by the user in the 'u2' parameter has not been exceeded **or**
- temperature difference between the solar collector (T1) and the isothermal tank (T2) is lower than the value set by the user in the 'u0' parameter and temperature difference between the collector (T1) and the swimming pool (T3) is a positive figure, bigger from the value set by the user in the 'u3' parameter and the maximal temperature in the tank of the swimming pool heat exchanger (T3) set by the user in the 'u2' parameter has not been exceeded.

**When the heat exchanger of the swimming pool is heated, operation of the PK main pump will be interrupted every 60 minutes to test temperature in relation to the condition of water heating in the isothermal tank (switching of the ZT valve)! Time of the interruption is set in user parameter 'u4' (where 0 means no interruptions if no testing of this condition is done).**

#### 8.5. A system with two collectors

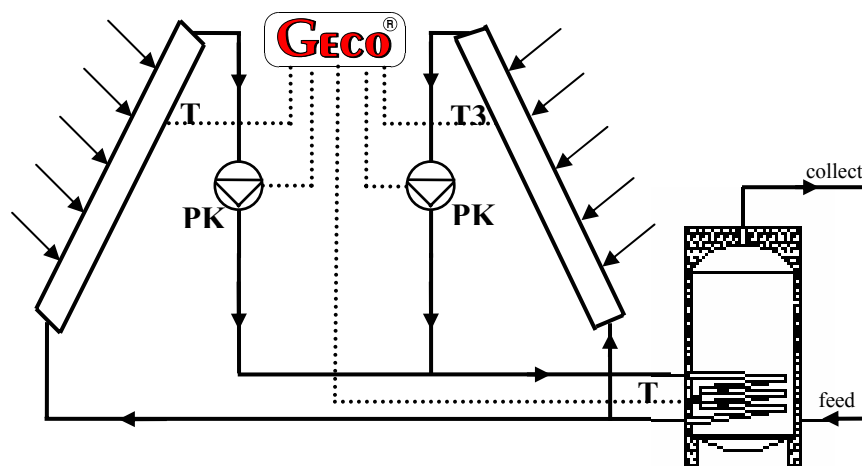

Fig. 5

**Parameters available to the user**

‘u0’: (scope 2-30 °C): temperature difference which controls operation of collector pumps

‘u1’: (scope 10-90 °C): maximal temperature of the isothermal tank above which collector pumps are switched off

In this system the collector pump functions in accordance with the description in item 5.3 and the PK2 collector pump is an additional pump. It is switched on if temperature difference between the second solar collector (T3) and the isothermal tank (T2) is a positive figure and is bigger than the value chosen by the user in the ‘u0’ parameter and the maximal temperature of the isothermal tank defined by the user in the ‘u1’ parameter is not exceeded.

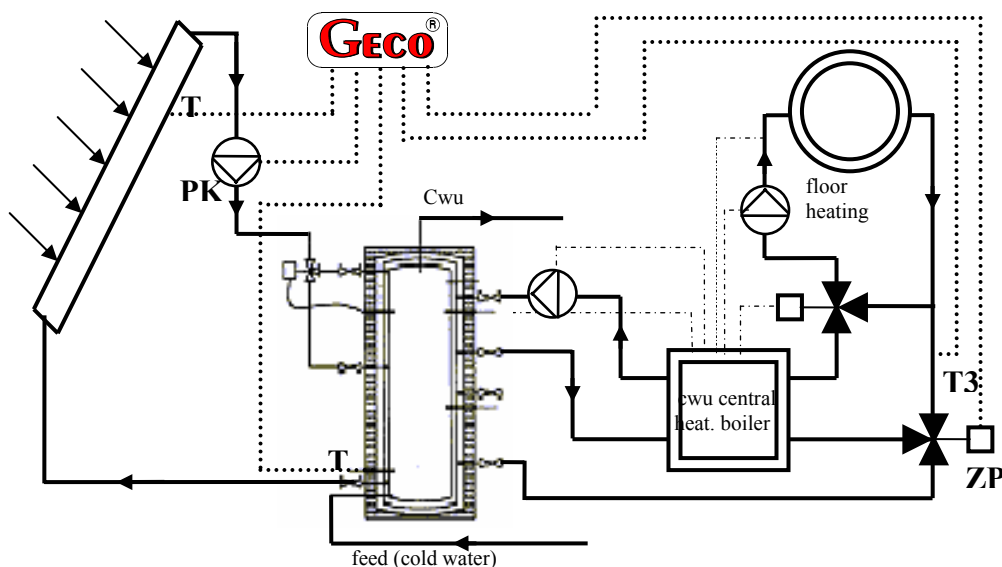
**8.6. A system with one collector and a floor heating system**

**Fig. 6**

**Parameters available to the user**

‘u0’: (range 2-15 °C) temperature difference which controls work of the main collector pump

‘u1’: (range 10-90 °C) maximal temperature of the isothermal tank above which the collector pump will be switched off

‘u2’ - (range 10-90 °C) maximal temperature of the floor heating above which the ZP valve will be shut off

‘u3’ – (range 2-15 °C) temperature difference which controls operation of the ZT tree-way valve

In this system the collector pump functions in accordance with the description in item 5.3 and the ZP three-way valve is an additional unit. It is opened when temperature difference between the isothermal tank (T2) and floor heating (T3) is a positive figure and is higher than the value defined by the user in the ‘u3’ parameter and the maximal temperature of floor heating (T3) set by the user in the ‘u2’ parameter has not been exceeded.



PRZEDSIĘBIORSTWO  
PRODUKCYJNO-USŁUGOWO-HANDLOWE  
Spółka z o. o.

ul. Zarzecze 112 A, 30-134 KRAKÓW POLAND  
tel. +48(12)6369811, 6361290  
fax. +48(12)6362002  
e-mail: geco@geco.pl  
http://www.geco.pl

**Complaint slip no. 1**  
for a temperature controller  
type G-403-P04

**I. DATA OF THE CONTROLLER:**

controller type: — .....

production date: — .....

module series number: — .....

panel series number: — .....

**II. DATA OF THE COLLECTOR:**

collector producer: — .....

collector type (capacity): — .....



PRZEDSIĘBIORSTWO  
PRODUKCYJNO-USŁUGOWO-HANDLOWE  
Spółka z o. o.

ul. Zarzecze 112 A, 30-134 KRAKÓW POLAND  
tel. +48(12)6369811, 6361290  
fax. +48(12)6362002  
e-mail: geco@geco.pl  
http://www.geco.pl

**Complaint slip no. 2**  
for a temperature controller  
type G-403-P04

**I. CONTROLLER DATA:**

Controller type: — .....

Production data: — .....

Module series number: — .....

Panel series number: — .....

**II. DATA OF THE COLLECTOR:**

collector producer: — .....

collector type (capacity): — .....

**SBR DAMAGE DETAILS:**

.....  
.....  
.....  
.....  
.....  
.....  
.....  
.....  
.....  
.....  
.....  
.....

.....  
Date and place of repairs  
requirement reporting

.....  
Serviceman signature  
and servicing station seal

-----  
**SBR DAMAGE DETAILS:**

.....  
.....  
.....  
.....  
.....  
.....  
.....  
.....  
.....  
.....  
.....  
.....

.....  
Date and place of repairs  
requirement reporting

.....  
Serviceman signature  
and servicing station seal

## 9. TROUBLESHOOTING

defect symptoms	check
1. The display is not lit although the controller is connected to mains	Check: <ul style="list-style-type: none"> <li>• whether voltage 230V is present on feeding terminals L and N</li> <li>• whether the connection of the performing module with the control panel is correct</li> <li>• pull out and put back the sockets of the band</li> <li>• connect another band</li> </ul>
2. The pump of the collector is not switched on although a green diode which signals it is on	check: <ul style="list-style-type: none"> <li>• whether voltage 230V is present on feeding terminals L as described on the upper wall of the performing module</li> <li>• whether the pump is not broken</li> <li>• whether the connection of the performing module with the control panel is correct</li> <li>• connect another band</li> </ul>
3. The additional pump is not switched on although a green diode which signals it is on	Check: <ul style="list-style-type: none"> <li>• whether voltage 230V is present on feeding terminals L as described on the upper wall of the performing module</li> <li>• whether the pump is not broken</li> <li>• whether the connection of the performing module with the control panel is correct</li> <li>• connect another band</li> </ul>
4. Wrong temperature indication	Check: <ul style="list-style-type: none"> <li>• Connection of the sensor to the coupling</li> <li>• whether the sensor is fixed correctly</li> <li>• condition of sensor cable; the cable <b>may not</b> have any damages</li> <li>• check in detail the outer surface of the shell of the sensor, i.e. whether it has not been damaged mechanically</li> <li>• connect another band</li> </ul>
5. 'abnormal' or 'strange' work of the controller	Check: <ul style="list-style-type: none"> <li>• whether voltage 230V is present on feeding terminals L and N</li> <li>• the condition of feeding couplings</li> <li>• the condition of electric installation and the number of units connected to one phase</li> <li>• whether the control panel, the performing module or plugs of the bands have not been wetted with water or other liquid</li> <li>• whether the control panel, the performing module or plugs of the bands are not exposed to dampness or sudden changes of temperature</li> <li>• whether the connection of the performing module with the control panel is correct</li> <li>• connect another band</li> </ul>
6. The display is flashing and it is impossible to switch it off	Check: <ul style="list-style-type: none"> <li>• The value of the feeding voltage</li> <li>• the condition of feeding couplings</li> <li>• whether feeding couplings are tightened up</li> <li>• whether the connection of the performing module with the control panel is correct</li> <li>• connect another band</li> </ul>



## Declaration of Conformity CE

We,

P.P.U.H. Geco sp. z o.o.  
Ul. Zarzecze 112A  
30-134 Kraków

declare with full responsibility that the product:

**controller G-406-P...**

conforms with provisions of the following directives:

73/23/EEC, 93/68/EEC  
89/336/EEC, 92/31/EEC, 93/68/EEC

and with the following harmonized standards:

PN-EN 60335-1:2002  
PN-EN 61000-6-1:2002, PN-EN 61000-6-3:2002  
PN-EN 60730-1:2002, PN-EN 60730-2-1:2002, PN-EN 60730-2-9:2004,

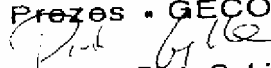
Prezes „GECO”  
  
mgr inż. Piotr Gębik

Piotr Gębik, MSc, Eng.  
Company President

Kraków, 30.06.2004

ZERTIFIKAT ◆ CERTIFICATE ◆ CERTIFICADO ◆ CERTIFICAT ◆  
 認 証 証 書 ◆

# CERTIFICATE



The Certification Body  
 of TÜV Management Service GmbH  
 certifies that

**PPUH**  
**"GECO" Sp. z o.o.**  
 PL-30-134 Kraków, ul. Zarzecze 112a

has established and applies  
 a Quality Management System for

**design, production, sales and service  
 of electronic measurement and control devices  
 for industrial automation and home appliances.**

An audit was performed, Report No. **70001206**  
 Proof has been furnished that the requirements  
 according to

**ISO 9001: 2000**

are fulfilled. The certificate is valid until **2007-04-30**  
 Certificate Registration No. **12 100 22047 TMS**

Munich, 2004-04-16

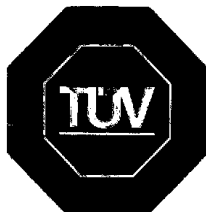

  
 Certification Body  
 of TÜV Management Service GmbH  
 Unternehmensgruppe TÜV Süddeutschland  
 Ridlerstraße 65  
 D-80339 München



TGA-ZM-07-92





P.P.U.H. „Geco” spółka z o.o.  
ul. Zarzecze 112 A  
30-134 Kraków POLAND  
tel. 012 6369811, 6361290  
fax. 012 6362002