

**The controller for central heating boilers with feeding screw**

**GH11RA**



**APPLICATION**

The GH11RA is a controller for central heating boilers with burners with feeding screw.

The GH11RA supervises the process of preparing hot utility water (HUW cycle), and allows to operate main heating circuit (central heating - CH cycle).

The GH11RA controller has been fitted for full communication with the GA01HA room panel (manufactured by GECO) which allows to control boiler operation comfortably from user's apartment.

**PROPERTIES**

- modern and functional visualisation of casing
- four-section display of the LED type
- single-module construction enables comfortable installation on the boiler
- cooperation with the HUW pump (Hot Utility Water)
- disinfection of the HUW cycle (Anti-Legionella function)
- HUW priority function
- cooperation with room panel (control boiler operation from user's apartment)
- SUMMER mode
- smooth control over fan rotations
- cooperation with reed relay (breaking cotter pin on the motoreductor)
- detection of maximum temperature in the burner feeder (flame moving back protection for the feeder)
- build-in temperature limiter STB
- sound signal of the alarms

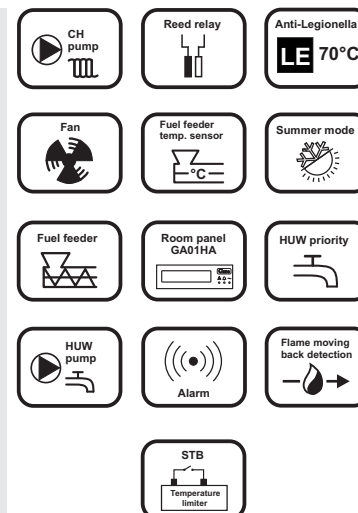

**INSTALATION ON THE BOILER**



# DIAGRAM OF CONNECTIONS

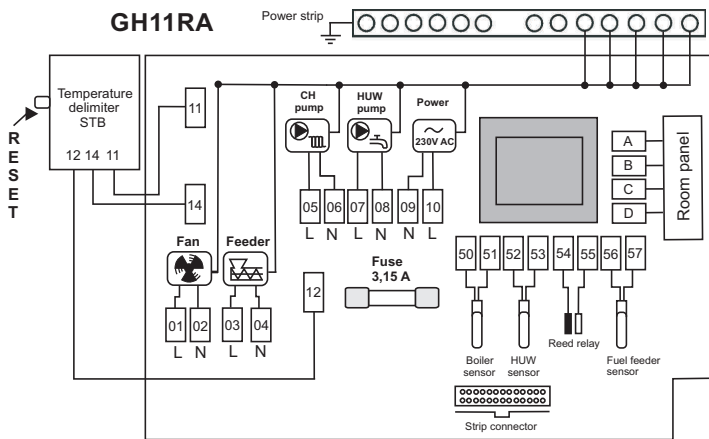
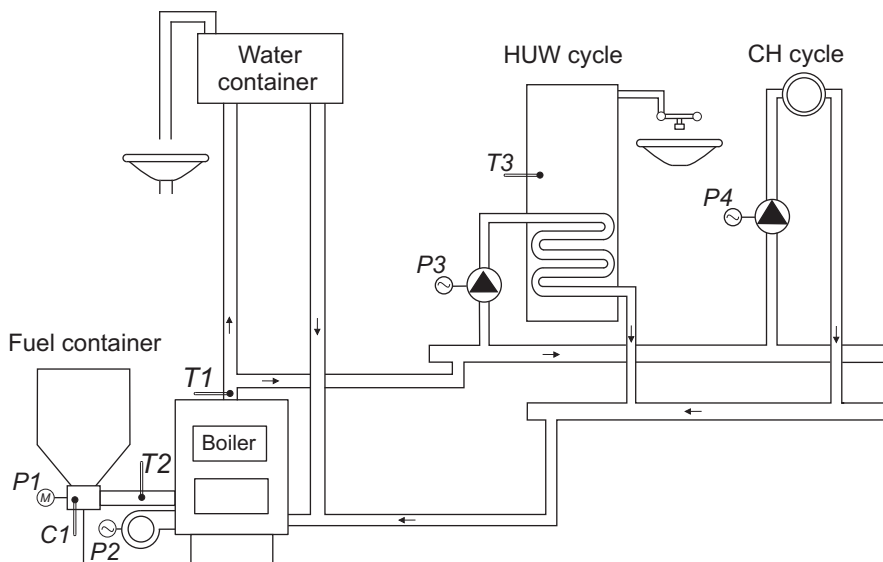

Diagram of electric connections					
Outputs			Inputs		
01	L	Fan	50,51	—	Boiler temperature
02	N	Fan	52,53	—	HUW temperature
03	L	Fuel feeder	54,55	—	Fuel feeder temp. sensor
04	N	Fuel Feeder	56,57	—	Reed Relay
05	L	CH pump	D	—	+12 V DC
06	N	CH pump	C	—	GND ⊥
07	L	HUW pump	B	—	RS-A
08	N	HUW pump	A	—	RS-B
09	N	Power 230V			
10	L	Power 230V			

# THE CONTROL AND HEATING SYSTEM



Controls	
P1	Fuel feeder
P2	Fan
P3	HUW pump
P4	CH pump
Sensors	
T1	Boiler temperature
T2	Feeder temperature
T3	HUW temperature
C1	Reed relay

# TECHNICAL DATA

Power supply voltage	230V AC +10%/ -15%
Fan and feeder protection	3,15A
Working temperature	from +5°C to + 40°C
Relative humidity	20% + 80% RH
Sensors type	NTC - range: from 0°C to +100°C

Output	Constant load	
Fuel feeder	2A	400W
CH pump	1A	200W
HUW pump	1A	200W
Fan	1A	200W

Temp. sensor (NTC) 2,2 kΩ	
°C	kΩ
0	7174,89
10	4374,83
20	2747,10
30	1774,91
40	1172,09
50	795,08
60	547,95
70	384,62
80	275,86
90	202,37
100	149,16

GH11RA equipment	
<b>Standard equipment:</b>	
1)	boiler temperature sensor
2)	fuel feeder temperature sensor
<b>Optional equipment:</b>	
1)	HUW temperature sensor
2)	reed relay
<b>Controls:</b>	
1)	fuel feeder
2)	CH pump
3)	HUW pump
4)	fan